

the  
sensitive  
shapes  
of the  
stone

LITHEA



*Lithea chooses to celebrate this special June edition of the Salone del Mobile 2022 through a reflection on the past, present and future. The topics presented are many and the completion of projects developed over the last two years - specifically the Pantelleria collection - and new productions that look towards the future of the company, under the artistic direction of the Martinelli Venezia studio.*

*Isola delle Correnti, in particular, is the result of research into the control of light through stone.*

*To this project are added the new accessories and coverings for the home and the bathroom that complete the Pantelleria collection, designed by the Martinelli Venezia studio and by Elena Salmistraro and interpret the suggestions of this small and wonderful island, nestled in the waters between Sicily. and Tunisia.*

*Pantelleria, also called the Black Pearl of the Mediterranean, known since the ancients who handed down the stories of a mysterious and extraordinary island, is considered an island of fertility, a land full of offers. An island with cliffs eroded by the sea and the wind, black volcanic lava rocks, green expanses of zibibbo vineyards, dry stone walls and the sea in all shades of blue: the designers, who both have a special bond with the Mediterranean, have interpreted these natural inspirations by designing tables and coffee tables, panels and modules for graphic and highly material wall coverings.*

*The new collections, formally more essential or hyper decorative, are designed for all indoor or outdoor environments, home and contract creations and enrich them with suggestions drawn from the particularity of Pantelleria landscapes.*

## Isola delle Correnti

design Martinelli Venezia

*Result of a research on the control of light through stone. The project consists of a wall lamp and a table lamp with a sculptural shape in which, simply by touching the marble surface with the hand, it is possible to switch on, off and modulate the intensity of the light source.*

*Isola delle Correnti, so named in homage to the small rounded island on the Ionian coast of Sicily. The table version consists of two parts, both CNC-cut and hand-finished in all their details: a solid base with a curved section that supports a thin cnc-sculpted cap on which there is a slight flat area that invites you to touch. This is a useful gesture for the functioning of the object but also to appreciate every time the stone, a precious natural material par excellence.*

### Materials

Bianco Carrara, Pietra Pece, Pietra Lavica, Bardiglio Imperiale, Nero Marquina

### Dimensions

table lamp 60x70x5 cm  
wall lamp 53x48x18 cm

Use indoor





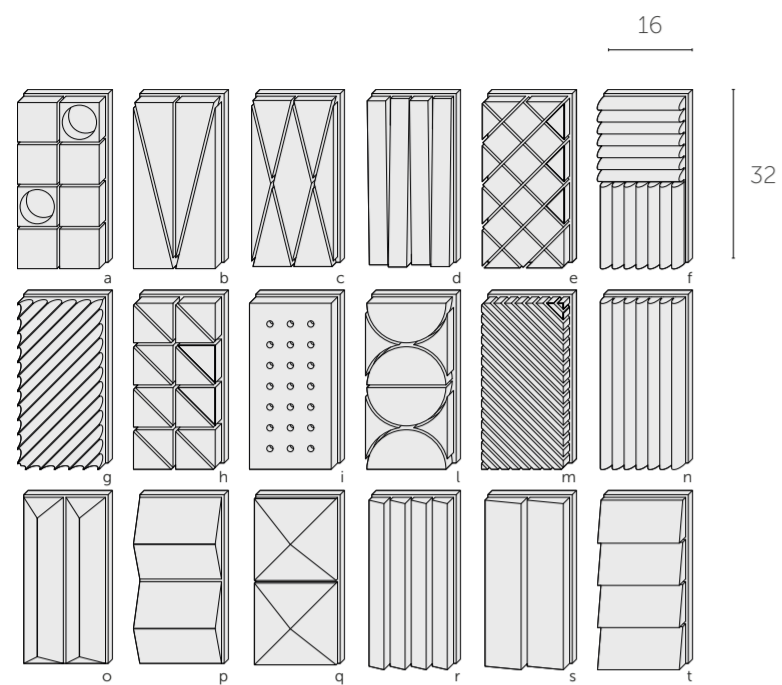

## Maioliche di pietra

design Martinelli Venezia

A collection of modular pietra lavica tiles characterised by three-dimensional design motifs that can be put together in various compositions. The idea for this design comes from the recollection of a small house-museum belonging to a majolica collector which was hidden in an eighteenth century building in the historical centre of Palermo. The 'maioliche di pietra' represent this idea: of what the Mediterranean symbolises, carved with skilled craftsmanship which sets apart Lithea's production from other companies'. These are rectangular pieces, small low-relief designs whose three-dimensional, geometric surfaces reminiscent of the grooved trunks of the columns, of the dry, stone walls, of the blocks of the mines from which they are extracted, of the squared or diamond-shaped renaissance Bossage, of the chiaro-scuro and play of light which are typical of the baroque period.

**Materials** Pietra lavica dell'Etna, Crema Tunisi, Bianco Carrara.  
**Dimensions** single tile 16x32x2 cm  
**Use** indoor, outdoor

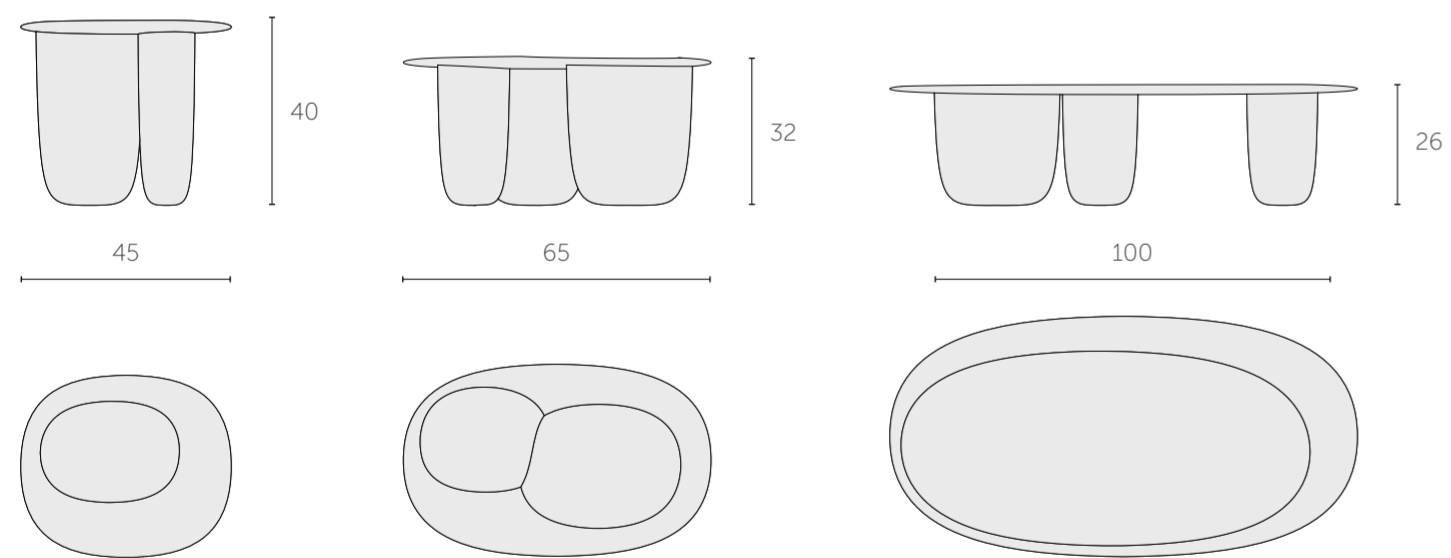

## Sesi

design Martinelli Venezia

Small, stone tables in different sizes and shapes, recognizable by their unique curved lines which resemble smooth pebbles with flint-like areas, placed one on top of the other like balancing building blocks on the seashore. They are named after the enigmatic, commemorative buildings, shaped like truncated cones or more precisely like the typical Sesi buildings found around the island of Pantelleria.

From a more formal view they represent a true technical challenge in terms of carving the material as a means to hide the thicker areas where the elements join together and also as a way to aesthetically lighten the look.

**Materials** Crema Tunisi, Bianco Carrara, Pietra Pece  
**Dimensions** S 45x45x40h cm, M 65x40x32h cm, L 100x51x26h cm  
**Use** indoor, outdoor









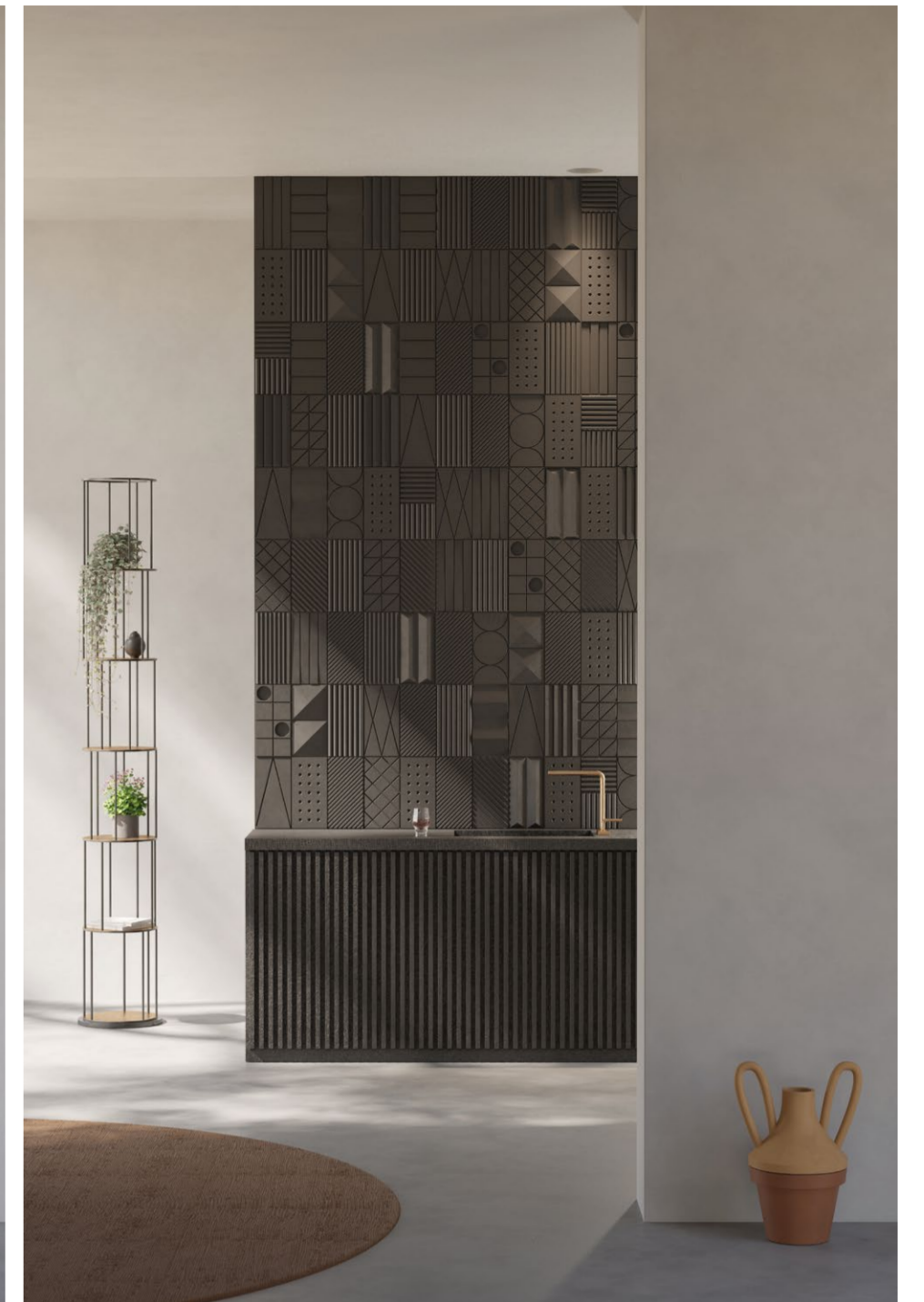



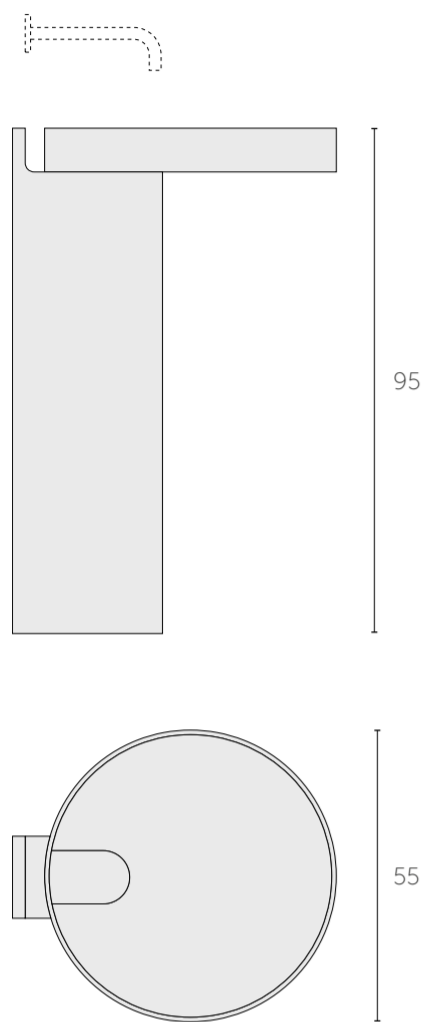

## lavabo Fontana

design Martinelli Venezia

Washbasin with essential geometry. The circular tank is positioned eccentrically with respect to the base. The simple shape makes it easy to integrate into any project.

**Materials** Bianco Carrara, Grigio Billiemi, Nero Marquina

**Dimensions** 51x61x95h cm

**Use** indoor

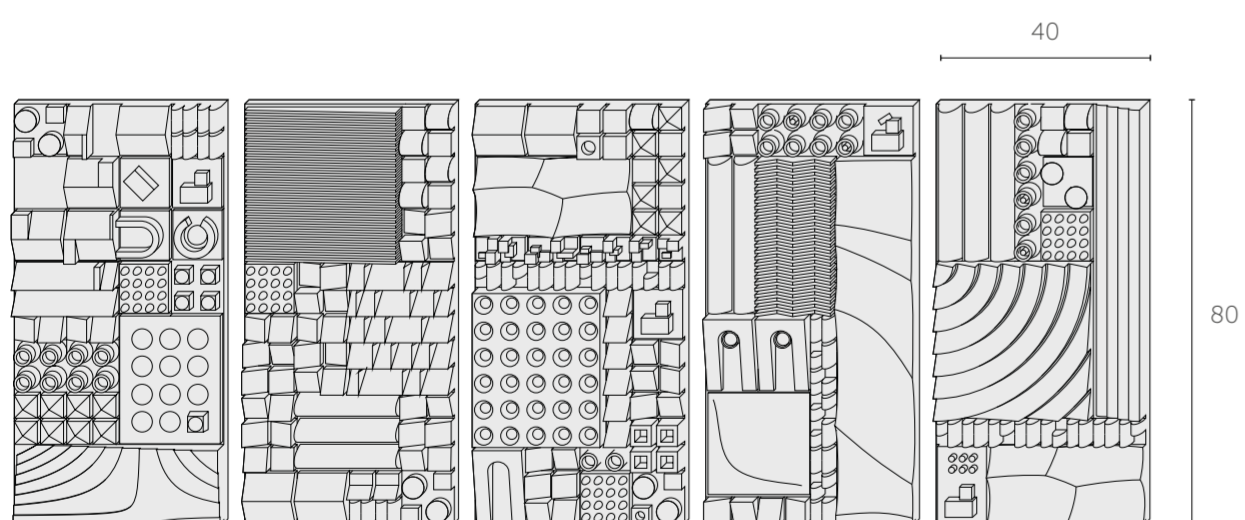

## Tracce

design Martinelli Venezia

Stone, modular wall covering inspired and engraved with typical elements from the Pantelleria landscape. Illustrations of the terracing farming, the blowholes of the Favare, the shape of the dammusi rooftops, the rows of Zibibbo have all been reinterpreted as though distant memories and printed on four different tiles that assembled create the finished product. Showcased in Nero Maquinia marble in honour of Pantelleria: the "Black Pearl" of the Mediterranean.

**Materials** Bianco Fenice, Bianco Carrara, Crema Tunisi, Grigio Tunisi, Bardiglio Imperiale, Pitchstone, Nero Marquina.

**Dimensions** 10 different tiles 40x80x2h cm

**Use** indoor, outdoor





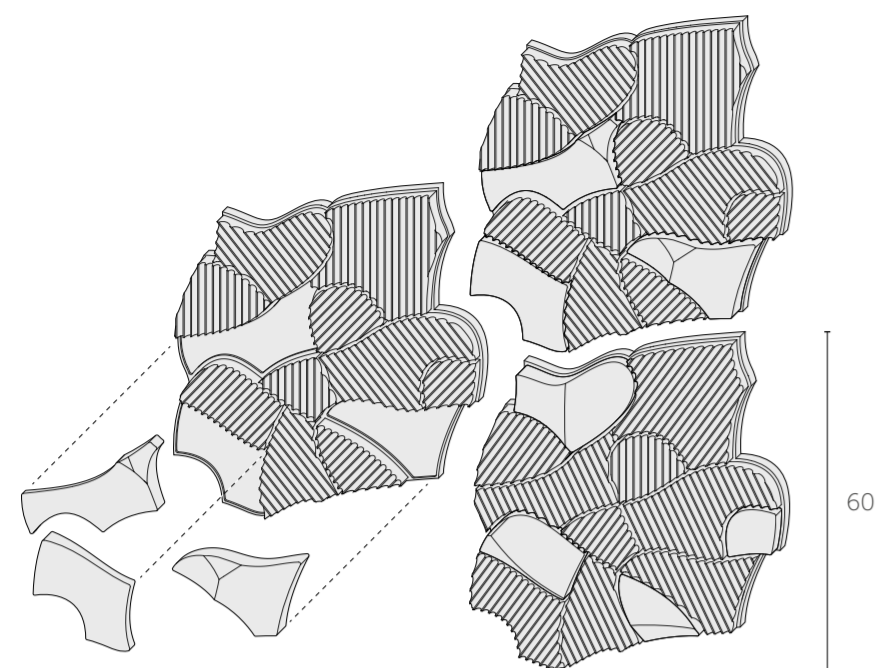

## terre arate

design Martinelli Venezia

*Modular, wall covering created by putting together irregularly shaped tiles that once assembled resemble the curved lines painted on the rooftops of the dammusi houses. Alternating smooth and concave parts with furrowed lines bringing to mind the rows of Pantelleria's vineyards. Created in homage to the Zibibbo tree that is cultivated in the typical valleys which protect them from the impetuous winds that blow on the island. The whole design is achieved with identical tiles creating a juxtaposition of the various elements that give the impression of a continuous and never-ending image.*

**Materials** Grigio Billiemi for the furrowed base with Pietra Pece inserts for the flint sculptured elements

**Dimensions** single tile 60x65,8 cm

**Use** indoor, outdoor

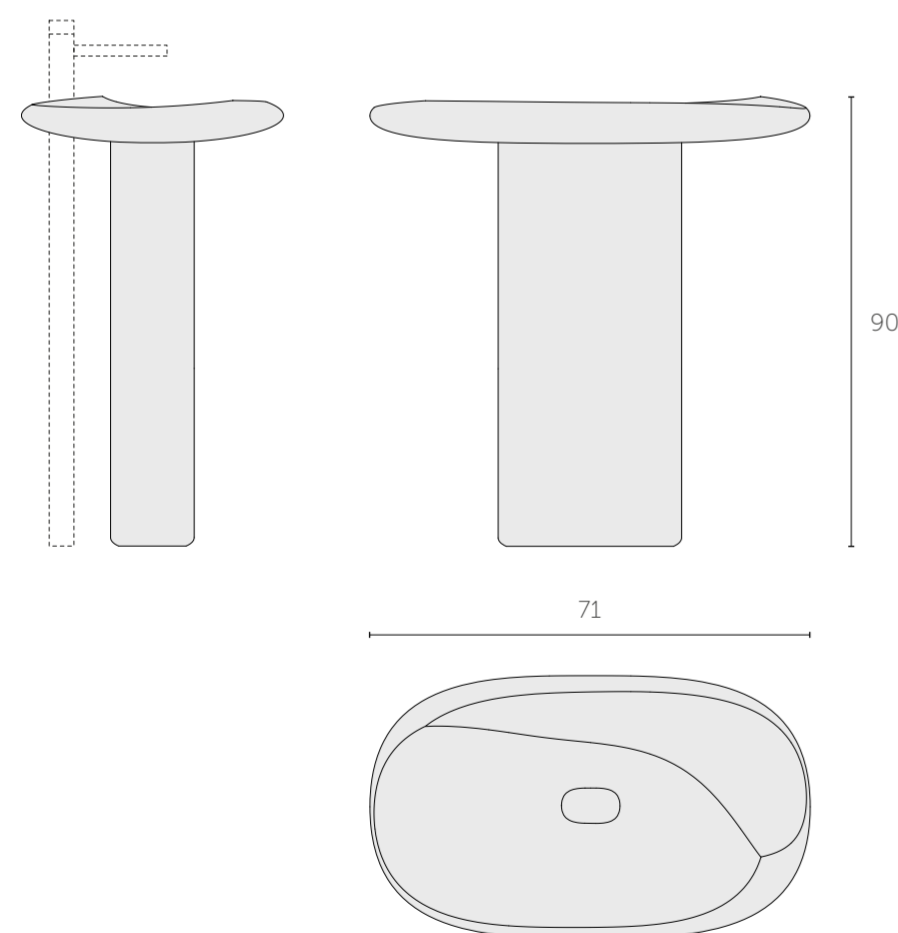

## lavabo Selce

design Martinelli Venezia

*Freestanding washbasin with a strong presence, takes its name from the rock used in the first human settlements. The shape of a large stone with similar strong cuts reminiscent of the chips of choice.*

**Materials** Bianco Carrara, Grigio Billiemi, Nero Marquinia, Pietra Pece

**Dimensions** 71x51x90h cm

**Use** indoor, outdoor





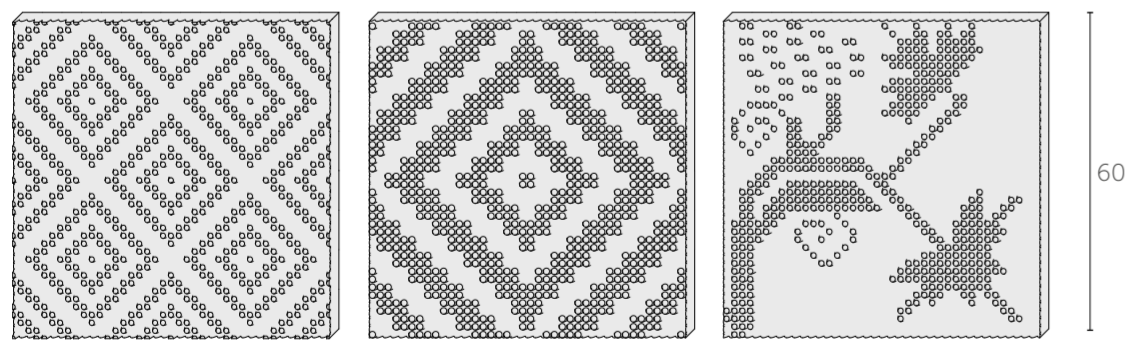

## Pibiones

design Pierluigi Piu

*The large stone tapestries are inspired by a traditional Sardinian weaving technique whose decorative motifs are characterized by stitched relief beads (pibiones) or grains, formed by small regular hoops produced using a loom. The vine branch or lapwing, which in Sardinia have always been considered symbols of prosperity and fertility, are in fact among the most recurrent stylistic features used by the Sardinian artisans in the decoration of traditional artifacts.*

**Materials** Bianco Fenice

**Dimensions** single tile 60x60x2h cm

**Use** indoor, outdoor







## Centocentrini

design Marella Ferrera

*The modular wall covering, designed by Marella Ferrera and impressed as fossils of geometries drawn from nature, is representative of a present affected by the past, and turned towards future. A Sicily displayed in the palette of its most important stones: from the molten rock to the Comiso stone, from the Pietra Pece to the Ragusa stone, from Palermo's one to Trapani's one.*

**Materials** Bianco Fenice, Bianco Carrara, Pietra Pece, Crema Tunisi

**Dimensions** three dimensional decorative panel 300x240x2h cm and 180x240x2h cm

**Use** indoor, outdoor



## Caltagirone

design Elena Salmistraro

*A reinterpretation of the exquisite Majolica pottery of Caltagirone, an abstract concept in which the decorative motif is modernised and stylised thanks to the use of Pietra Pece*

**Materials** Pitchstone, with a free-style manual application of copper leaf using the mordant gilding technique

**Dimensions** three dimensional decorative panel 300x500 cm

**Use** indoor, outdoor



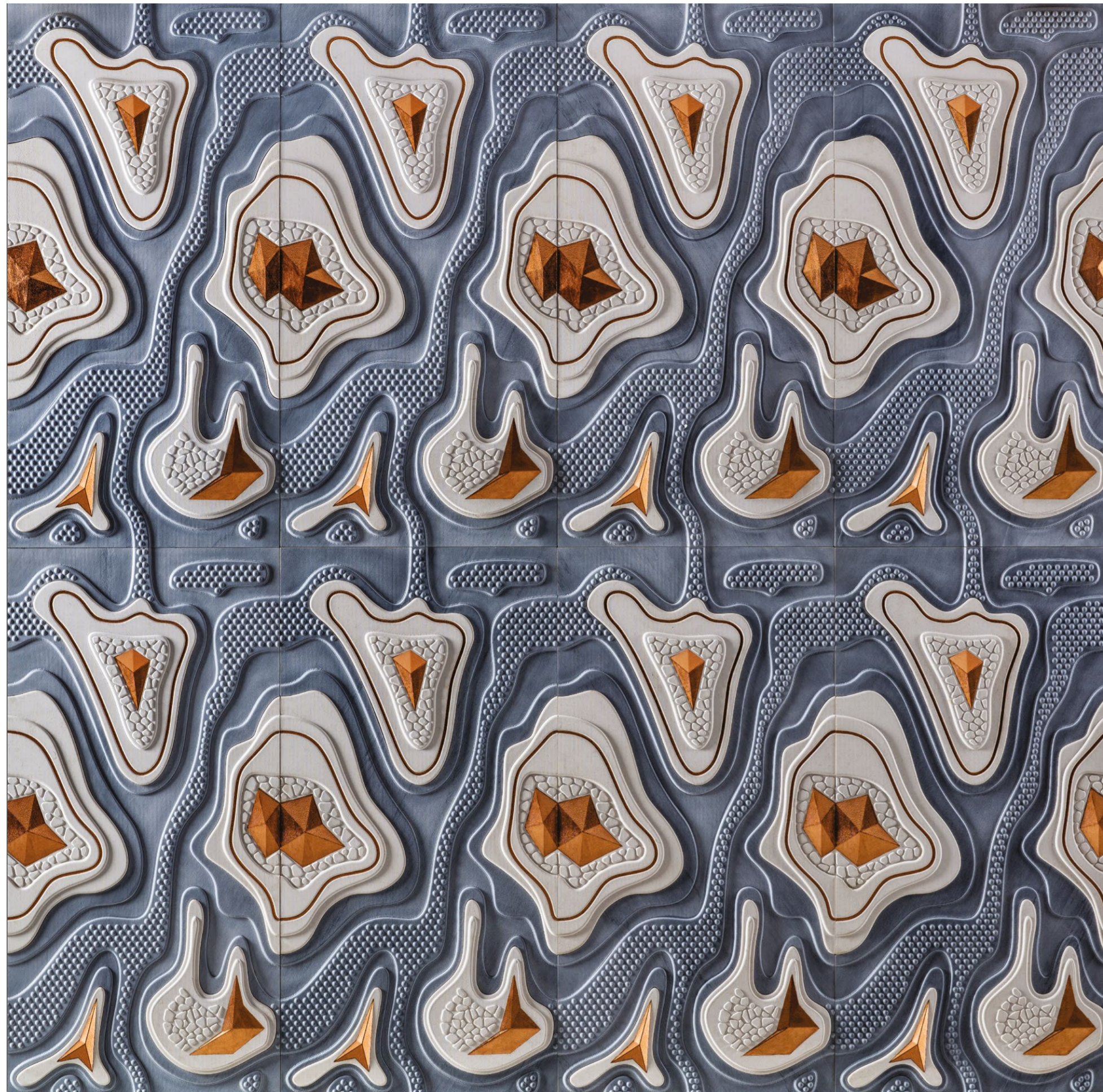

## Favare

design Elena Salmistraro

*Decorative wall panel with a particular three-dimensional aesthetic reminiscent of the Favare, the intriguing sprays of volcanic steam that come out of the subsoil*

**Materials** the light blue base is made from Bardiglio Imperiale marble, the elements are in Bianco Fenice with manually applied copper leaf  
**Dimensions** single tile 120x60x3 cm  
**Use** indoor, outdoor





## Gadir

design Elena Salmistraro

*Cala Gadir, a term of Arabic origin which means 'Valley of water' is a location known since old times for its natural hot water springs and still nowadays is one of the most well-known locations of the Island of Pantelleria. The great central basin is surrounded by Pantelleria's typical rounded gardens, fields, vineyard-covered cliffs, quarries that slope down to the sea and layered rock. This panel brings together inlays, grafts and bas-relief, all the natural elements which are unique to this island. On a Bianco Fenice stone base, engraved with an undulated design, soft, geometrical elements are inserted into marble of various colours and texture, finished and applied manually. The panel is further decorated and embellished through the application of small, copper elements.*

**Materials** Bianco Fenice, Bardiglio Imperiale, Pietra Pece, Rosalia, Forrest Green and Copper

**Dimensions** Three dimensional decorative whole panel 240x240 cm, single marble slab 120x60x3 cm

**Use** indoor, outdoor

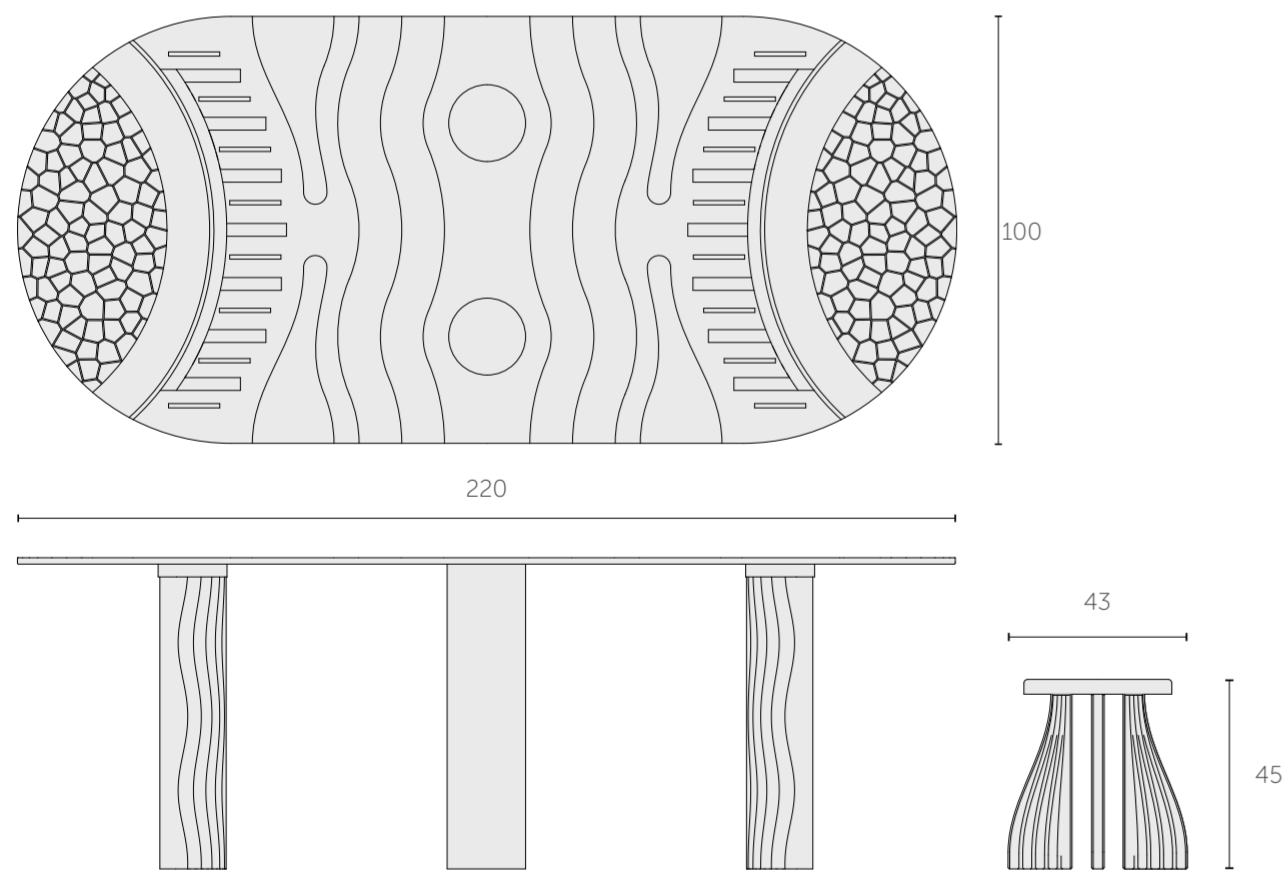

## Specchio di Venere e Sibà

design Elena Salmistraro

*The table Specchio di Venere, features an elegant top with rounded edges, resembling the colours and shape of the famous lake which came from a volcanic crater in the island of Pantelleria.*

**Materials** Bianco Fenice, Bianco Carrara, Crema Tunisi, Grigio Tunisi, Bardiglio Imperiale, Pitchstone, Nero Marquinia.

**Dimensions** table 220x100x73h cm, stool 43x43x45h cm

**Use** indoor, outdoor





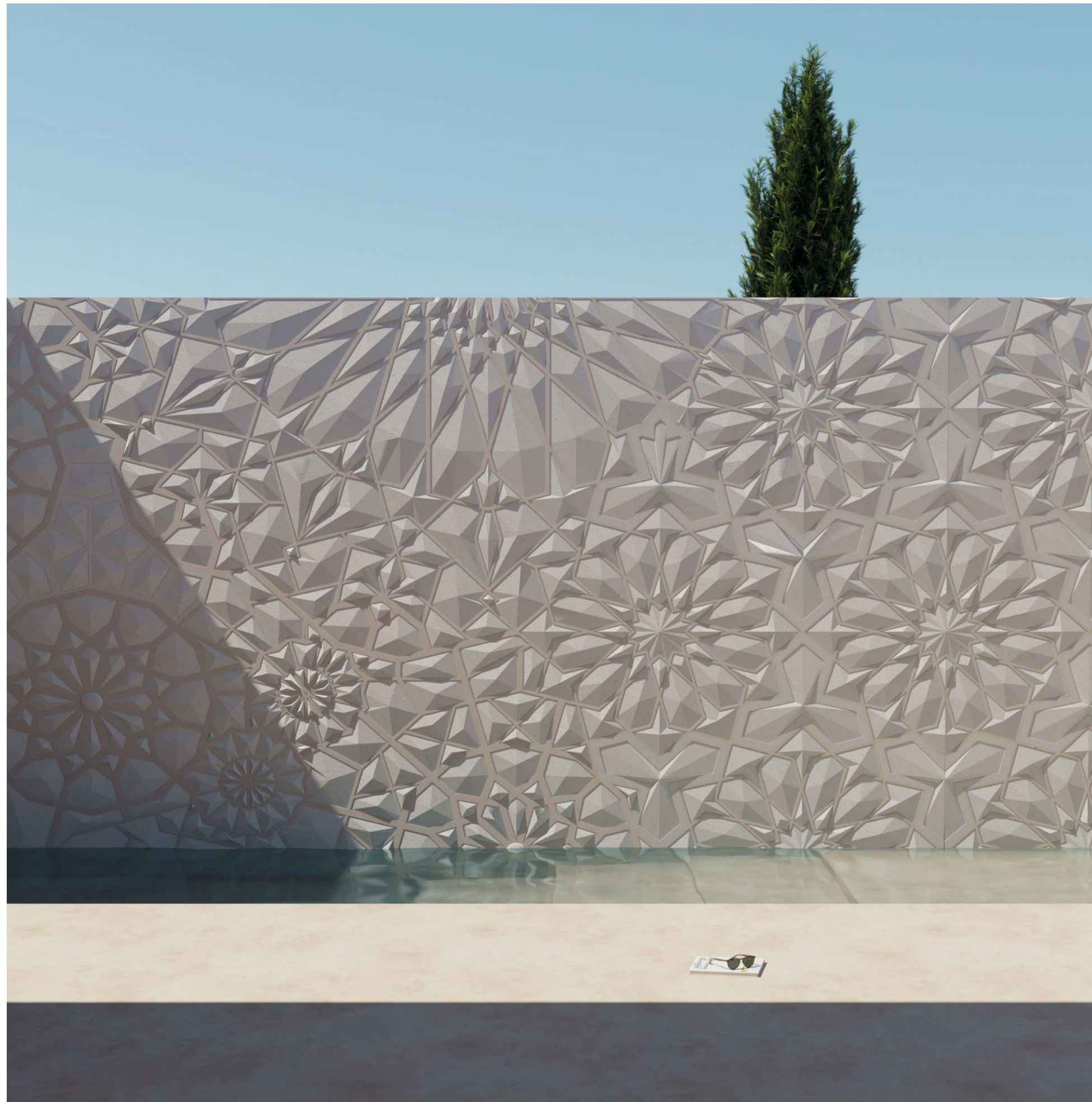

## Monreale

design Elena Salmistraro

*Geometric arabesques are repeated, overlapped and layered just like the artistic history of Monreale, where both European culture and Arab culture mix, and which give birth to a contemporary, three-dimensional texture*

**Materials** Bianco Carrara with copper sheets inserts  
**Dimensions** three-dimensional decorative panel 300x500 cm  
**Use** indoor, outdoor





